

Spherical roller bearings

R00	MA250919	GR250919
-----	----------	----------

23128 CAW33S1

Main boundary dimensions (mm)	
d	140
D	225
B	68

Technical data			
Basic load ratings (kN)	Dyn.	C_r	663
	Stat.	C_{0r}	898
Mass (kg)		10,5	
Cage material		Brass	
Radius min (mm)	r₁	2,1	
	r₂	2,1	
	r₃	-	
	r₄	-	
Precision class		P0	
e		0,28	
Bearing clearance (mm)		CN	

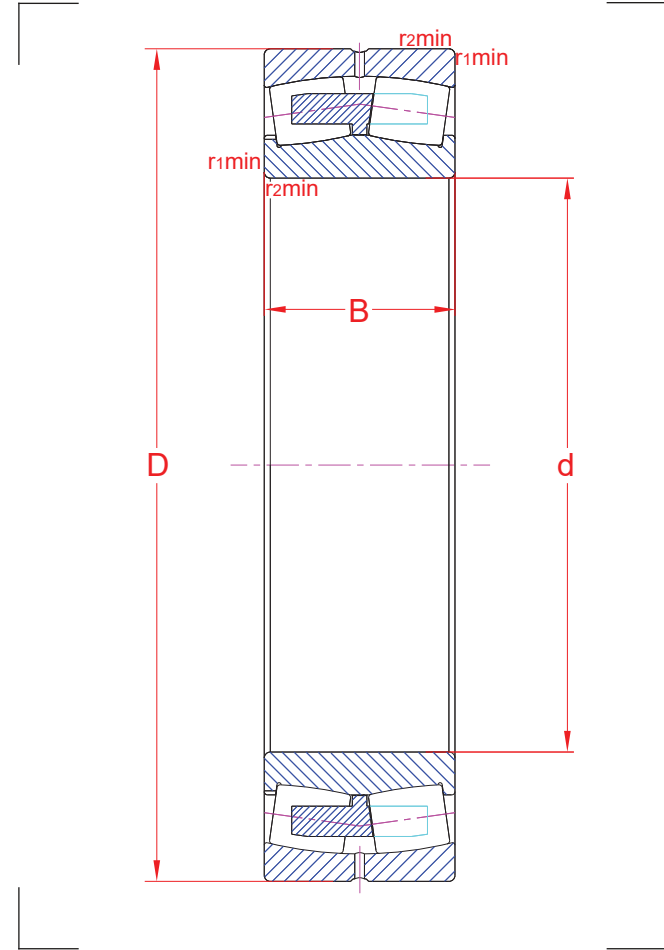

Technical notes
<ul style="list-style-type: none"> - Reference speed 2000 rpm - Limiting speed 2500 rpm - Double pronged machined brass cage - Annular groove and lubrication holes in outer ring - Bearing rings heat stabilized for operating temperatures up to 200 °C - For general industry purpose

The sketch is for reference only and may not be representative or indicative of the actual product. Sketch scale is free.

Also refer to RKB Affidavit of Conformance for related compliance to International Standards.

Every care has been taken to ensure the accuracy of the information in the present drawing, but no liability can be accepted for any errors or omissions contained herein, or in case losses and/or damages (direct, indirect, consequential) should occur.

RKB Bearing Industries reserves the right of any amendment without notice.

RUNI-BF-YLS-H