

Single row taper roller bearings

R01	MA090718	RD090718
-----	----------	----------

30209 XE

Main boundary dimensions (mm)	
d	45
D	85
T	20,75
B	19
C	16

Technical data			
Basic load ratings (kN)	Dyn.	C_r	82,5
	Stat.	C_{0r}	76,0
Mass (kg)		0,47	
Cage material		Pressed steel	
Radius min (mm)	r₁	1,5	
	r₂	1,5	
	r₃	1,5	
	r₄	1,5	
Precision class		Normal	
e		0,40/K factor 1,46	
Bearing clearance (mm)		-	
Configuration/Design		302/X/E	

Technical notes
<ul style="list-style-type: none"> - Through hardened steel for rings and rollers (SAE 52100) - Reference speed 5700 rpm - Limiting speed 6970 rpm - Cage max protrusion 2,6 mm (cup large face side) and 4,3 mm (cup small face side) - Optimized internal design with reinforced execution - For general industry purpose

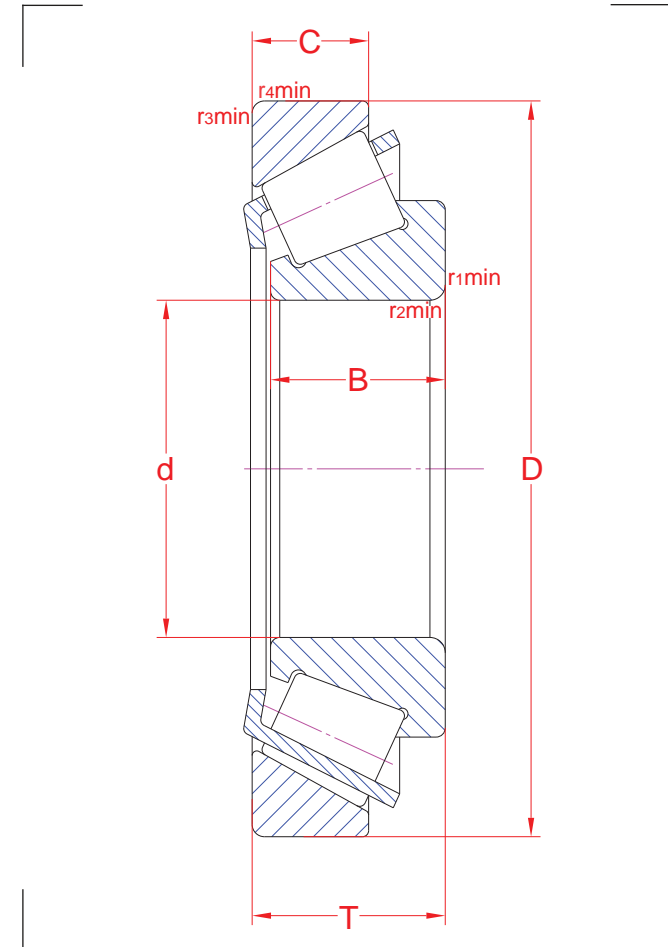

The sketch is for reference only and may not be representative or indicative of the actual product. Sketch scale is free.

Also refer to RKB Affidavit of Conformance for related compliance to International Standards.

Every care has been taken to ensure the accuracy of the information in the present drawing, but no liability can be accepted for any errors or omissions contained herein, or in case losses and/or damages (direct, indirect, consequential) should occur.

RKB Bearing Industries reserves the right of any amendment without notice.