

Single row taper roller bearings

R01	MA281019	GR281019
-----	----------	----------

30211 E

Main boundary dimensions (mm)	
d	55
D	100
T	22,75
B	21
C	18

Technical data			
Basic load ratings (kN)	Dyn.	C_r	110
	Stat.	C_{0r}	105
Mass (kg)		0,7	
Cage material		Pressed steel	
Min chamfer dimensions (mm)	r₁	2,0	
	r₂	2,0	
	r₃	1,5	
	r₄	1,5	
Precision class		Normal	
e		0,40	
K		1,44	
Bearing clearance (mm)		-	

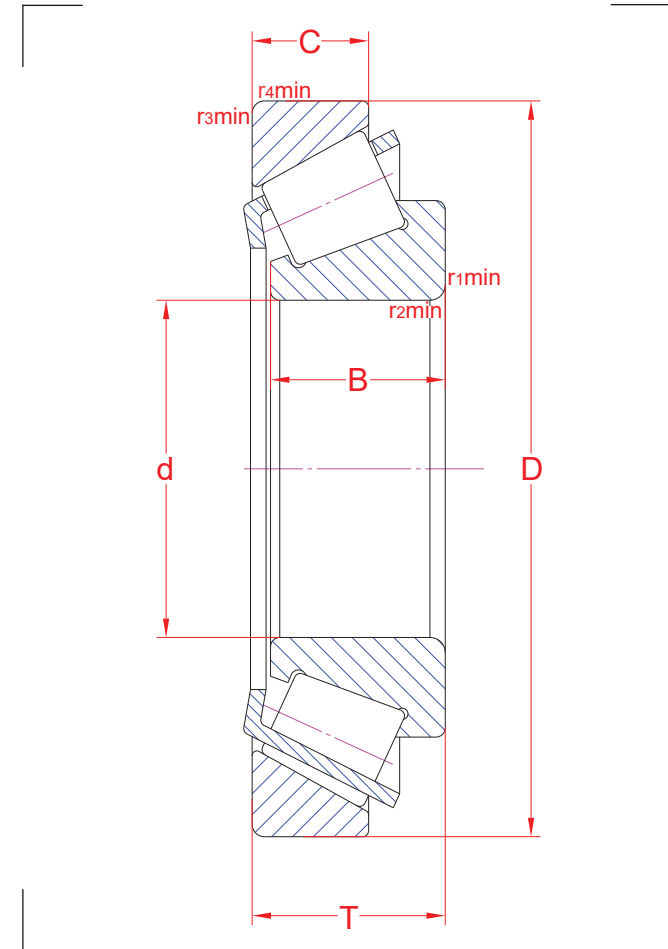

Technical notes

- Through hardened steel for rings and rollers (SAE 52100)
- Cage max protrusion 1,55 mm
- Reference speed 5000 rpm
- Limiting speed 5790 rpm
- Optimized internal design with reinforced execution
- For general industry purpose

The sketch is for reference only and may not be representative or indicative of the actual product. Sketch scale is free.

Also refer to RKB Affidavit of Conformance for related compliance to International Standards.

Every care has been taken to ensure the accuracy of the information in the present drawing, but no liability can be accepted for any errors or omissions contained herein, or in case losses and/or damages (direct, indirect, consequential) should occur.

RKB Bearing Industries reserves the right of any amendment without notice.