

Single row taper roller bearings

R01	LT220318	MA/RD220318
-----	----------	-------------

30304 E

Main boundary dimensions (mm)	
d	20
D	52
T	16,25
B	15
C	13

Technical data			
Basic load ratings (kN)	Dyn.	C_r	41,1
	Stat.	C_{0r}	31,9
Mass (kg)		0,17	
Cage material		Pressed steel	
Radius min (mm)	r₁	1,5	
	r₂	1,5	
	r₃	1,5	
	r₄	1,5	
Precision class		Normal	
e		0,30/K factor 1,95	
Bearing clearance (mm)		-	
Configuration/Design		303/E	

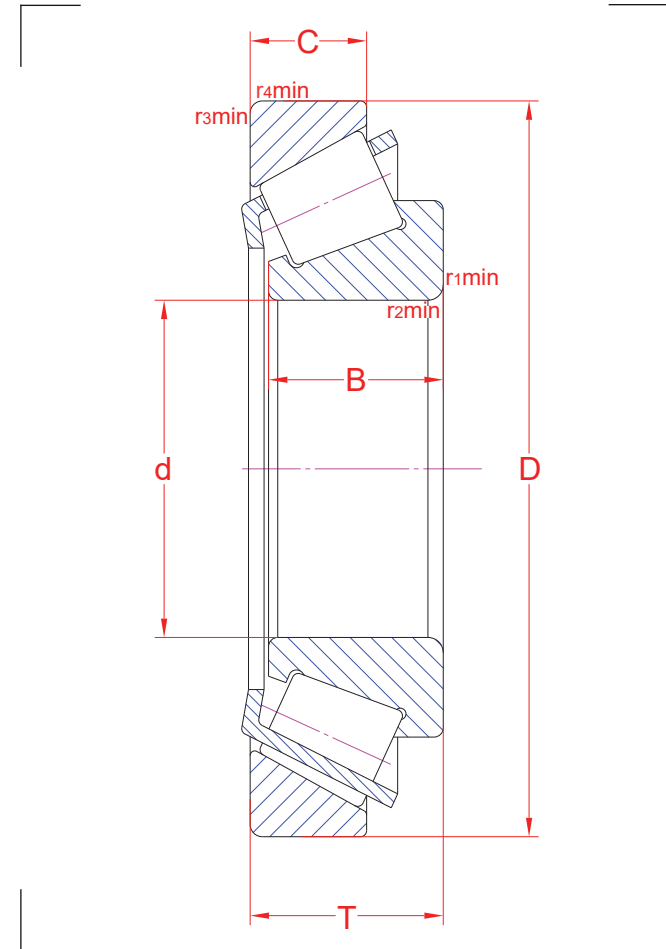

Technical notes

- Reference speed 11400 rpm
- Limiting speed 11900 rpm
- Optimized internal design with reinforced execution
- For general industry purpose

Sketch scale is free.

Also refer to RKB Affidavit of Conformance (LJSA) for related compliance to International Standards.

Every care has been taken to ensure the accuracy of the information in the present drawing but no liability can be accepted for any errors or omissions contained herein, or in case losses and/or damages (direct, indirect, consequential) should occur. RKB Bearing Industries reserves the right of any amendment without notice.