

Inner ring

OV100216

L 314190 A2DXS1A/1

Main boundary dimensions (mm)	
d	160
F	180
B	130

Technical data		
Basic load ratings (kN)	Dyn.	C_r -
	Stat.	C_{Or} -
Mass (kg)	5,5	
Cage material	-	
Radius min (mm)	r_1	1,5
	r_2	1,5
	r_3	-
	r_4	-
Precision class	Special P6	
e	-	
Bearing clearance (mm)	-	
Configuration/Design	L/A2DX/A	

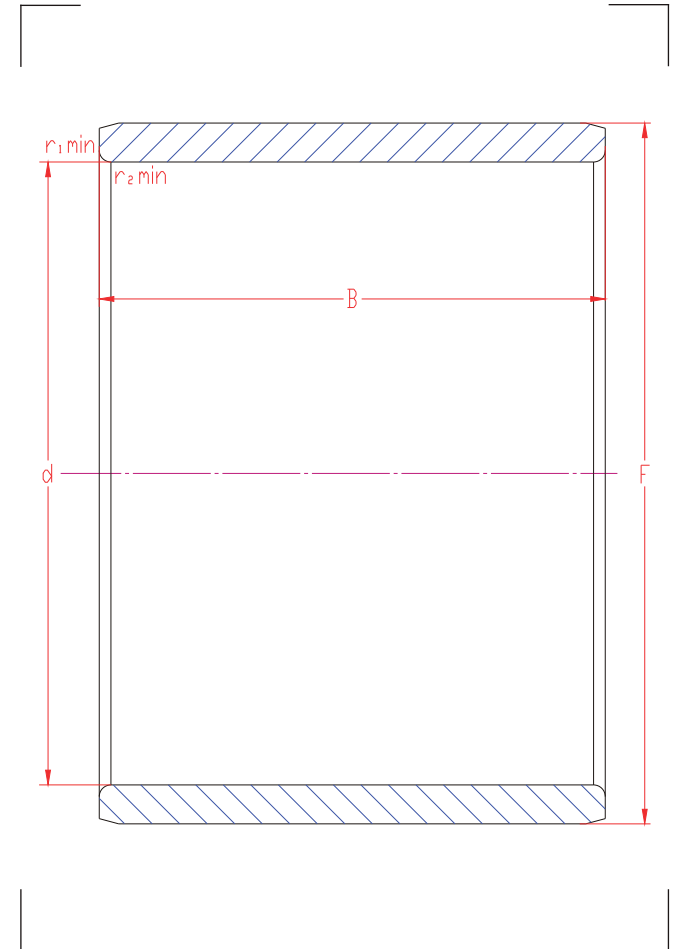

Technical notes

- Through-hardened steel (RKB SAE52100) with bainite treatment for extended service life
- Execution in one piece
- Chamfer on F dimension 5,0x15°
- Ring dimensionally stabilized S1
- Application: rolling mill stand/ steel industry

Sketch scale is free.

Also refer to RKB Affidavit of Conformance (LJSA) for related compliance to International Standards.

Every care has been taken to ensure the accuracy of the information in the present drawing but no liability can be accepted for any errors or omissions contained herein, or in case losses and/or damages (direct, indirect, consequential) should occur. RKB Bearing Industries reserves the right of any amendment without notice.