

Cylindrical roller bearings

R01	MA090421	GR090421
-----	----------	----------

NU 226 EM

Main boundary dimensions (mm)	
d	130
D	230
B	40
F	153,5

Technical data			
Basic load ratings (kN)	Dyn.	C_r	421
	Stat.	C_{0r}	450
Mass (kg)		7,31	
Cage material		Brass	
Min chamfer dimensions (mm)	r₁	3,0	
	r₂	3,0	
	r₃	3,0	
	r₄	3,0	
Precision class		P0	
e		-	
Bearing clearance (mm)		CN	

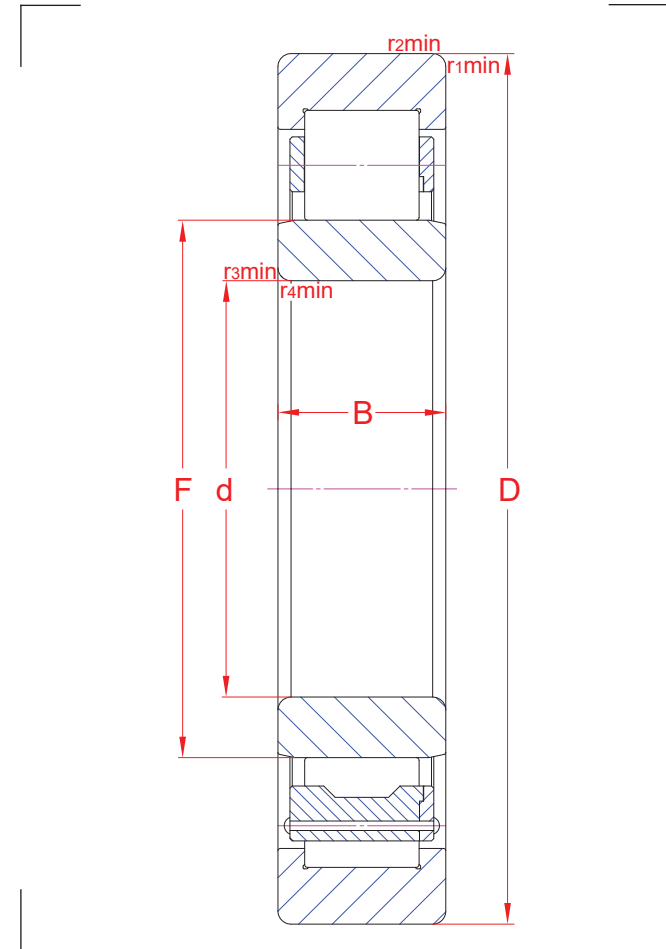

Technical notes
<ul style="list-style-type: none"> - Reference speed 2900 rpm - Limiting speed 2900 rpm - Permissible axial displacement 2,1 mm - Optimized internal design with reinforced execution - Optimized roller profile for improved load distribution - Machined brass cage guided on rollers - For general industry purpose

The sketch is for reference only and may not be representative or indicative of the actual product. Sketch scale is free.

Also refer to RKB Affidavit of Conformance for related compliance to International Standards.

Every care has been taken to ensure the accuracy of the information in the present drawing, but no liability can be accepted for any errors or omissions contained herein, or in case losses and/or damages (direct, indirect, consequential) should occur.

RKB Bearing Industries reserves the right of any amendment without notice.