

Cylindrical roller bearings

| | | |
|-----|----------|----------|
| R01 | GR090718 | MA080719 |
|-----|----------|----------|

NU 2308 E

| Main boundary dimensions (mm) | |
|-------------------------------|----|
| d | 40 |
| D | 90 |
| B | 33 |
| F | 52 |

| Technical data | | | |
|-------------------------|----------------------|-----------------------|-----|
| Basic load ratings (kN) | Dyn. | C_r | 128 |
| | Stat. | C_{0r} | 118 |
| Mass (kg) | | 0,94 | |
| Cage material | | Pressed steel | |
| Radius min (mm) | r₁ | 1,5 | |
| | r₂ | 1,5 | |
| | r₃ | 1,5 | |
| | r₄ | 1,5 | |
| Precision class | | P0 | |
| e | | - | |
| Bearing clearance (mm) | | CN | |

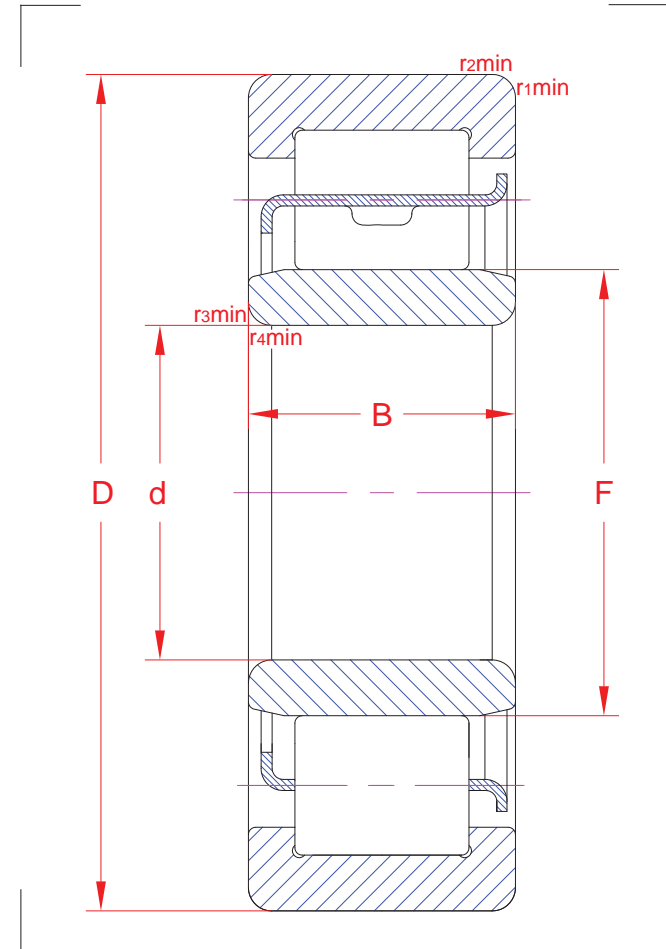

| Technical notes |
|--|
| <ul style="list-style-type: none"> - Reference speed 7700 rpm - Limiting speed 8300 rpm - Permissible axial displacement 2,9 mm - Optimized internal design with reinforced execution - Optimized roller profile for improved load distribution - For general industry purpose |

The sketch is for reference only and may not be representative or indicative of the actual product. Sketch scale is free.

Also refer to RKB Affidavit of Conformance for related compliance to International Standards.

Every care has been taken to ensure the accuracy of the information in the present drawing, but no liability can be accepted for any errors or omissions contained herein, or in case losses and/or damages (direct, indirect, consequential) should occur.

RKB Bearing Industries reserves the right of any amendment without notice.